

Leaky Feeder Cable

Leaky feeder is an antenna technology originally designed to deliver radio services in tunnels. If your car radio continues to work as you pass through a long tunnel is likely that a leaky feeder installation is involved.

As its name implies leaky feeder is a cable which leaks a small amount of the radio signal throughout, just like a hosepipe with holes drilled at intervals along its length. Leaky feeder cable is also often called Leaky Coaxial or LCX cable.

At Solwise our interest in the technology stems from a number of WiFi installations where conventional access-point and antenna combinations have proved troublesome. For instance, a hotel with long corridors and solid concrete floors and walls can require an access point in every room or several scattered down the corridor in order to ensure reliable WiFi for every guest. An installation such as this would be expensive in hardware costs, tricky to install and hard to manage and maintain. A traditional multi-AP type installation would also raise potential issues with client roaming and user confusion when they see several wireless networks.

A leaky feeder installation, perhaps in the suspended ceiling of the hotel corridor, can replace many access-points with just one, feeding a leaky cable over the length of the corridor. The signal from the cable would pass through the wooden doors providing a service to every room. Using a single AP in this way makes the entire wireless network appear as a single WiFi network which greatly simplifies connectivity and roaming issues for the users.

Below shows a rough picture of how the signal would typically be propagated down a corridor if a multiple Access Point scenario was used.

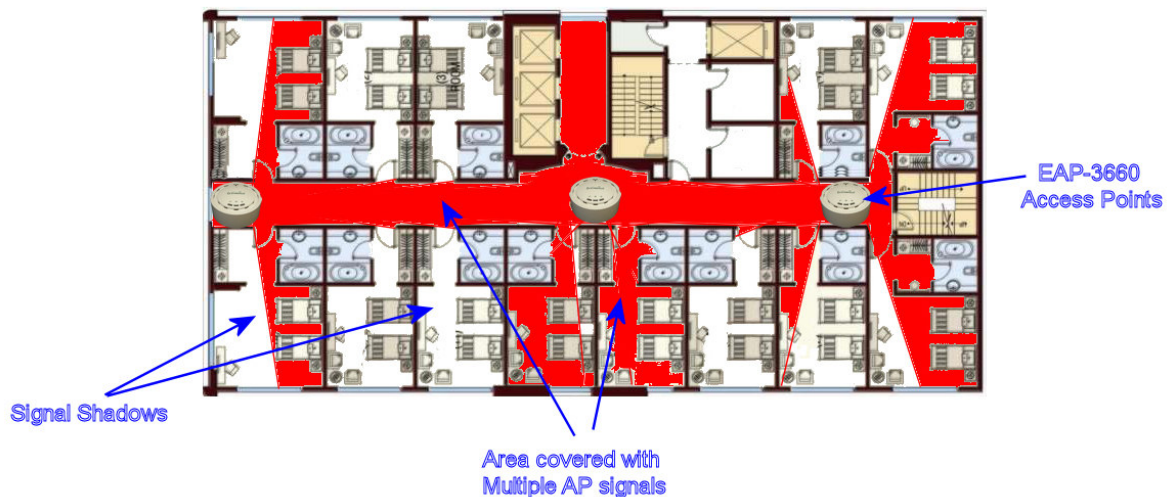

Because of shadows caused by the walls of the rooms and corridor then coverage in those rooms out of line of site of an AP can be very poor. The red areas show where the signal is very strong but note the shadows where signal is not reaching.

Compare this with the sort of coverage an LCX system can provide.



With LCX cable running down the ceiling of the corridor then coverage is much more complete. Basically any point that can 'see' the cable can receive a good signal.

From the above you can see, in a multiple AP setup, as long as you are in line of site of one the AP's then you get an excellent signal; in fact a signal which is almost certainly much stronger than is required. On the other hand, with the LCX setup, due to the distributed nature of the signal from the leaky antenna then the signal is evenly broadcast down the entire corridor bathing the whole area in a medium gain signal. Although the absolute strength of the signal from the LCX is lower than that which might be given in direct line of site of an AP, the fact that the LCX system gives a higher, more uniform coverage with much reduced shadow effects, results in an overall much better solution.

Another example of a difficult WiFi installation is a warehouse or cold-store where stored product creates canyons into which radio signals cannot penetrate. A leaky feeder cable above each canyon or hanging from ceiling joists can be a cost-effective one-stop solution.

Leaky Feeder Installations

Consider again the 'hosepipe with holes'. In order to ensure that water spurts out of the holes at the end of the pipe with the same gusto as it did at the start, we have to make sure that lots of water pressure is available, and that the holes along the length are very small. Clearly, if we started with a low pressure and large holes all the water would leak out at the start and after a few metres the garden would go thirsty.

Similarly, leaky feeder cable has the equivalent of small holes. It is engineered so that the radiated signal is small compared to the signal which passes through. For example our NET-WL-LF-RMC50 leaky feeder cable connected directly to an access point would appear to a nearby client as an antenna with a gain of about -10dB. Losses along the cable amount to 0.16dB per metre, so 50 metres further along, the leaky feeder is looking like an antenna with a gain of -18dB.

To compensate for these low levels of radiated signal it is normal to use a higher power level at the access point. Bearing in mind that clients will normally be less than about 10 metres from the leaky feeder cable, WiFi power of 400mW (26dBm) to 1W (30dBm) is likely to give adequate performance. A decent AP (like the EnGenius ECB3610 or 3500) with upwards of 26dBm of power would make a 30m length of LCX cable appear as a continuous chain of medium power AP's equipped with traditional small antenna; ideal for client connectivity up to five or ten metres away. Should even longer runs be required then Specialist boosters are available which also improve signal sensitivity on the return signal from the clients. The Solwise NET-WL-PA2.4G/2W booster is also line powered and could be used to daisy-chain another run of leaky feeder to the end of the first if you want to run *real* long runs.

Another method you can use to drive a longer length of cable is to use an AP with two antenna connections running with diversity e.g. the EnGenius ECB3500:

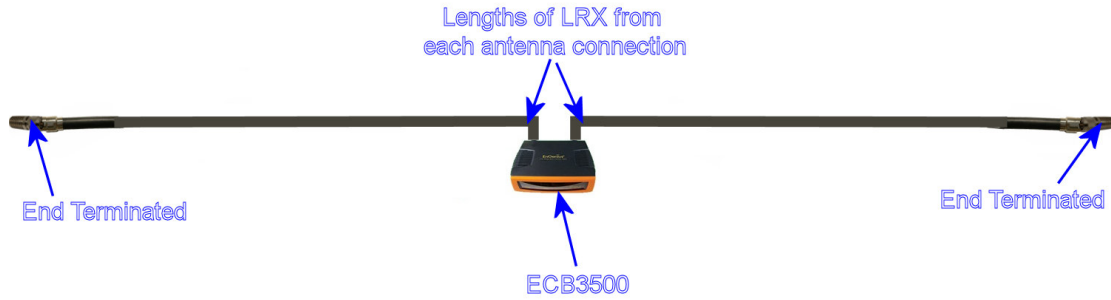

This allows you to run a double length of LCX cable from the same AP without requiring a signal booster or such. Please note if you want to run two lengths this way then the AP must be able to run true, full diversity i.e. it can transmit and receive from both antenna connections.

The final active component which is worth mention at this point is the radio equivalent of the sturdy bung which must be used to seal the end of our hosepipe. This 'RF-bung' is called a terminator (as indicated above).

Most of the radio energy which was originally launched into the cable ends up in the terminator, warming it up. The Solwise CON-N-RMC50-TERM terminator can dissipate up to 5 watts (37dBm).



Technical Description

A leaky coax cable is very similar to normal coaxial cable in its construction. The major difference is in the cable's outer conductor. Normal coaxial cables use outer conductor shields that are designed to minimize RF leakage. However, the outer conductor of a typical leaky coax cable has holes or openings in the outer conductor to allow a controlled amount of RF signal to leak out into the surrounding environment. Although most of the signal still travels through the cable, these openings allow the signal to radiate out from the cable creating an RF field around the cable.

Leaky coaxial cables have been used for many years as wireless feeders in coal mines and vehicular tunnels. More recently, leaky coax has started to be used as an antenna for in-building wireless systems for hard-to-cover areas such as lift shafts, office block or hotel corridors, warehouses, and building-to-building tunnels.

The LCX cable is of a type called 'radiating mode' leaky cable. This has a copper foil outer conductor with nonuniformly spaced slots arranged in a periodic pattern which radiates the RF in free space.

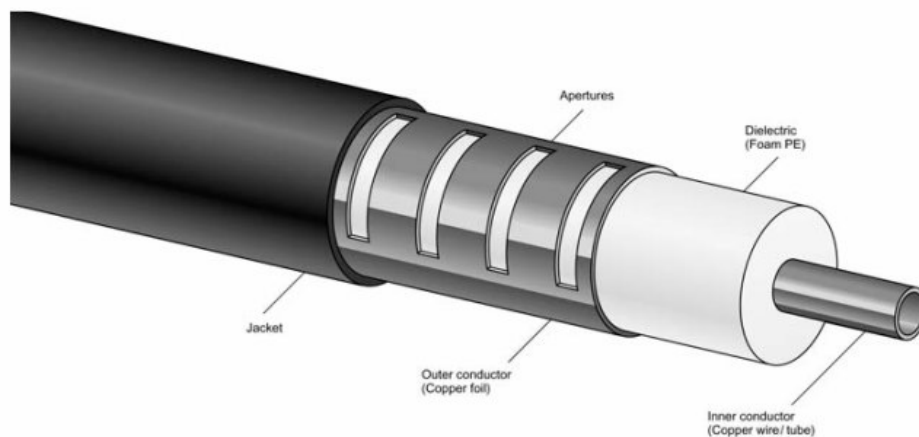

Schematic showing construction



**Sample of LCX showing the outer jacket removed
Note periodic slots in outer conductor**

Because of the design of LCX cable it is not possible to create a detailed model of scattering. Directional or point-source antennas, by design, have strong signal levels near the antenna and the signal levels get weaker as you move away from the antenna. They also tend to yield more line-of-sight radiation characteristics. This effect creates shadowing and uneven signal distribution. However, LCX cable emits a low-level signal and provides a uniform distribution of signal around the cable. Point-source antennas such as omni or patch and panel antennas are very practical and recommended for distribution of RF signals in large open areas. However, for more congested areas such as narrow aisles, tunnels, and confined environments LCX can give far superior coverage: Better to have a decent signal you CAN pickup rather than an over strong signal that you cannot because you are in a shadow.

Installation Considerations

The RF slots on the LCX cable are cut on just one side of the outer conductor so that the signal is mainly emitted on that side. Thus the signal covers roughly 180 degrees on the side with the RF slots. To ensure correct orientation the 'back' (non-signal) side of the cable has an indicator strip so installation should be done with the non-striped side facing where you want the signal to go. To avoid interference problems you should also ensure that the back of the cable stands at least 10cm from any wall or RF reflective surface. Another consideration is the bend radius i.e. how tight a bend can you do with the cable? The RMC50 cable has a bend radius of about 30cm which means total bend diameter of about 60cm; any tighter than this and you run the risk of buckling the inner conductor in the cable.

The cable is fairly heavy at just under a Kilo per metre. This shouldn't cause any problems with most suspended ceilings or roof joists however please do take this into consideration and ensure you correctly assess the load bearing capabilities of the area where the cable is to be installed.

Signal Tests

Tests were carried out to determine the real life signal strength and range of LCX cable compared to a traditional Access Point+'rubber-duck' omni antenna.

Two signal generators were used:

The first was an Airhorn signal generator.

For the second signals were generated using an EnGenius ECB-3220 high power AP (in fact three units were used to check for variations in signal strength between units) using the standard 3dBi antenna.

For absolute signal measurements we used an Aaronia HF-4040 analyser using a HyperLog 7040 0dBi antenna. For direct measurements a narda Micro-Pad 4778 30dB attenuator was connected.

We also used a DELL Vostra notebook using a built-in 1490 Dual Band WLAN card.

A miscellaneous collection of connectors, adapters and short pigtailed was used to connect systems together.

A 10m length of LCX cable was prepared with N type sockets and one end fitted with a 50Ohm terminator.

Testing output power of Airhorn and the Access Points

The Airhorn signal generator was connected directly to the HF-4040 analyser via a 30dBi attenuator. The Airhorn system was then configured to send a constant signal on Channel 11. The HF-4040 was

simultaneously set to scan the Channel 11 frequency range 2450-2474GHz and the maximum signal strength was recorded.

The results indicated that the output power of the Airhorn device was c. 14dBm \pm 0.5dBm.

We also tested output power of the Airhorn by indirect connection i.e. by antenna connection. To do this we fitted a 5dBi antenna to the Airhorn and then a HyperLog 0dBi antenna to the HF-4040 (using no attenuator). The HF unit was setup 2m away from the Airhorn and configured to again scan Channel 11. We then monitored the received signal and adjusted the attitude of the HyperLog antenna until the maximum signal was measured.

A signal of -27dBm \pm 0.5dBm was detected. Free Space Loss for the 2m separating the two antenna is calculated as -46dBm. This enables us to determine a true output power as -27+46-5(for the Airhorn antenna)dBm i.e. 14dBm \pm 0.5dBm.

Thus signal power by direct connection is in agreement with that obtained via wireless connectivity.

Similar tests were then carried out using the EnGenius NCB-3220 as signal source. The 3220 was configured to use Channel 11 802.11b at 'Extreme' power setting (nominally 26dBm) and, to ensure a constant transmission output from the AP, the DELL computer was wirelessly linked to the AP wireless network and a high speed data transfer carried out over the wireless connection.

Using a direct connection from the HF analyser to the antenna socket of the AP with a 30dB attenuator we measured a signal strength of 26dBm \pm 0.5dBm (after making allowance for the attenuator in the link). We then fitted a 3dBi antenna to the NCB-3220 and the 0dBi HyperLog antenna to the HF analyser and performed signal strength measurements at a separation of 2m. Our tests gave a maximum signal of -17dBm \pm 0.5dBm with a free space loss of -46dBm. This enables us to determine a true output power as -17+46-3(for the AP antenna)dBm i.e. 26dBm \pm 0.5dBm.

Thus signal power by direct connection is in agreement with that obtained via wireless connectivity.

Airhorn output power +14dBm \pm 0.5dBm

NCB-3220 output power+26dBm \pm 0.5dBm

Testing the signal Received from LCX

Next tests were done using both the Airhorn and NCB-3220 as output devices connected to the 10m length of LCX cable. The LCX cable was laid out across the wooden subfloor and raised off the ground by approximately 200mm using cardboard boxes.

The HF analyser was then setup with the HyperLog antenna aimed at the LCX cable at a distance of 2m perpendicular with the cable and approximately 2m from the start of the cable. The LCX cable was laid such that the transmission side of the cable was aimed at the measuring antenna.

Then the Airhorn was connected to the LCX via a 1dB loss pigtail and configured to constantly transmit. We then adjusted the attitude of the HyperLog antenna to give the maximum measured signal on the HF analyser. The maximum reproducible signal detected was -44dBm \pm 0.5dBm. With a free space loss of -46dBm this gives an effective output power of about 2dBm from the LCX cable. Some consideration was then given to the signal loss from the point where the Airhorn was connected to the LCX to the point where the signal was measured. This was a distance of approximately 2m which, at 0.16dBm/m, would give a signal loss in the cable of about 0.32dBm. However, since our measurements are typically only accurate to \pm 0.5dBm then this small cable loss can be ignored.

We then carried out the same test but using our 26dBm NCB-3220 as signal source again connected to the LCX cable using a 1dB loss pigtail. In this case the measured signal at 2m was -32dBm \pm 0.5dBm. With a free space loss of -46dBm this then gives the signal strength at the LCX cable of approximately +14dBm \pm 0.5dBm. This is in agreement with the signal measured from the LCX using the Airhorn as signal source: The 3220 has 12dBm more power output than the Airhorn so we would expect the output signal to be 12dBm higher for the 3220 i.e. 14dBm.

Results

Gain of the LCX antenna cable is given by

$$Gain_{LCX} = P_{Out} - P_{In} + fsl$$

Where P_{Out} is the measured signal power from the cable and P_{In} is the signal power from the signal generator (after connection cables losses) and fsl is the Free Space Loss. To be 100% correct we should take into account the insertion loss in the LCX cable but, as explained above, this is low enough to ignore in these tests.

So, taking the results using the Airhorn we see

$$Gain_{LCX} = -44 - 13 + 46$$

So $Gain_{LCX} = -11 \pm 1\text{dBi}$

These results are also well within experimental error of the quoted coupling loss for the cable of typically 60dB at 2.4 GHz.

$$CouplingLoss_{LCX} = \frac{P_{In}}{P_{rcv}}$$

This is the ratio of signal power going into the cable over the power of the received signal at 2m.

So $CouplingLoss_{LCX} = 13\text{dBm}/-44\text{dBm}$

i.e. 57dB

Considering the crude methods used in the experiments described here, the figure of 57dB compares very favourably with the published specification of 60dB for this cable.

Results Discussion

The results show that LCX cable has a gain of about -11dBi. Compared to the gain of antenna fitted as standard on a typical Access Point of about +2dBi this might be considered a little bit low. However there are additional issues to be considered other than looking at just antenna gain. Firstly the effective signal strength can easily be boosted by using an Access Point with higher than standard power. For example an EnGenius Access Point like the NCB-3220 and ECB-3610 has up to 6 or 8dBm higher output power than a typical brand AP. However, the most important issue is not outright power: It's how the signal is propagated. Consider the shape of the signal beam from LCX cable compared to that the beam given out by a traditional low gain omni or even a ceiling antenna. Both an omni and ceiling antenna are excellent at close range with the omni giving a 'doughnut' shaped beam and the ceiling antenna a wide, downward directed cone, however both beam shapes suffer with being very localised i.e. a very strong signal if you are within the area of the beam but considerably less effective if you are 'off' beam or not in line of site. Compare this to the beam shape from LCX which can be considered as a continuous cylinder of medium gain signal down its entire length with a deep dimple at the back of the cable. This means that the area within the vicinity of the LCX cable, at any point down its length, is covered by a uniform beam of low to medium gain. Further, in a typical application environment such as the corridor in a hotel or a warehouse, traditional designs of antenna can run into problems if the client is out of site of the antenna. However LCX cable is designed to be strung along the whole area such that clients within the vicinity of the cable have good connectivity where ever they are.

As an aside, a simple link budget shows that the signal from an LCX setup using a high power AP has more than enough signal to go 50m to a typical laptop. So given the improved coverage given by an LCX setup, using Leaky Feeder antenna cable is ideally suited to applications where when you need to cover large areas but only need short to medium range.